



Malaguti

IDEE IN MOTO

F 12 LC 2D RESTYLING KAT EURO 2 (2002 - ZJM 62)



TELAIO - INDICE TAVOLE

FRAME - INDEX OF THE TABLES

TAV. A 	TAV. B 	TAV. C-D 	TAV. E 	TAV. F
TAV. G 	TAV. H 	TAV. I 	TAV. L 	TAV. M
TAV. N 	TAV. OO 	TAV. O 		

MOTORE - INDICE TAVOLE

ENGINE - INDEX OF THE TABLES

TAV. R 	TAV. R1 			
------------	-------------	--	--	--

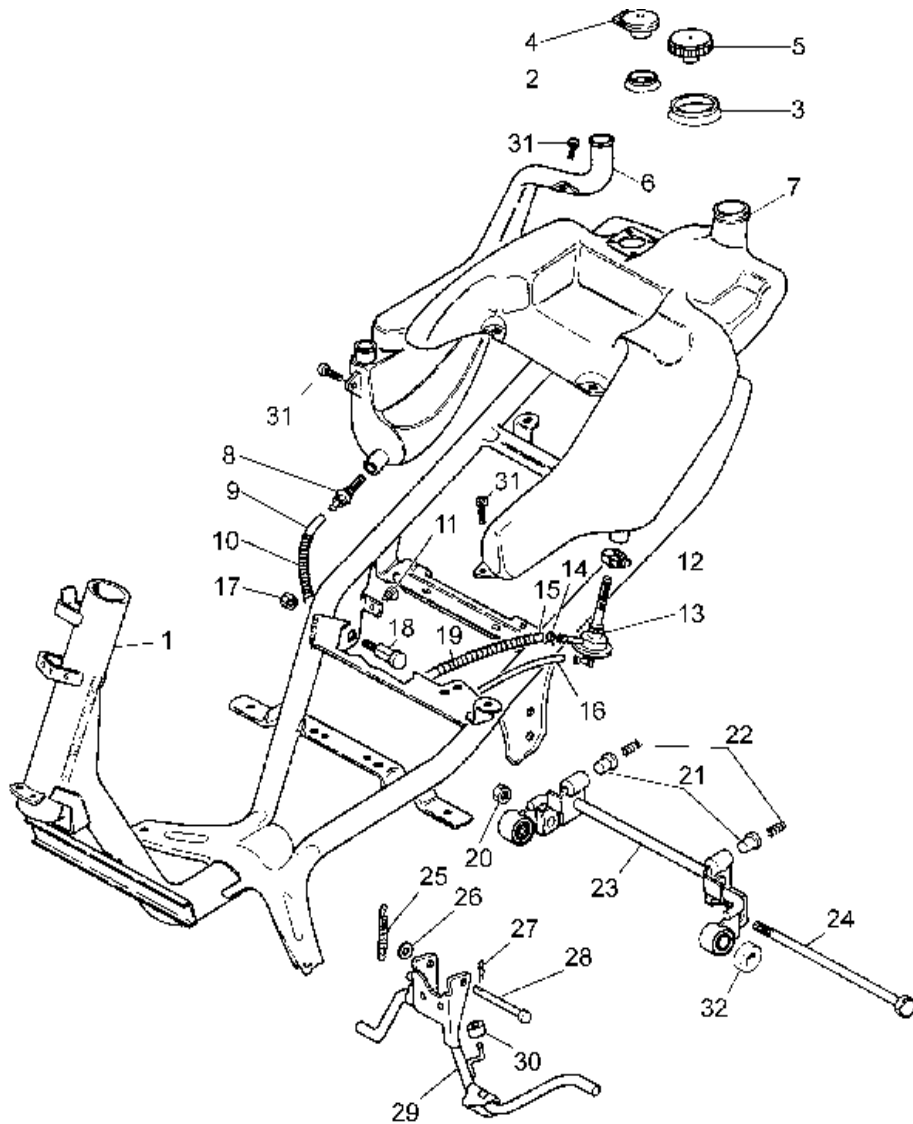

Nr.	Codice	Q.tà	Descrizione
1	156.071.99	1	Telaio
2	071.441.03	1	Coperchio tappo serbatoio olio
3	071.442.03	1	Coperchio tappo serbatoio benzina
4	071.144.00	1	Tappo serbatoio olio
5	092.016.03	1	Tappo serbatoio benzina
6	069.014.00	1	Serbatoio olio
7	161.060.00	1	Serbatoio benzina
8	094.007.00	1	Raccordo olio
9	180.003.54	1	Tubo olio
10	147.102.13	1	Molla tubo olio
11	072.066.03	2	Gommino antivibrante
12	167.031.00	1	Fascetta stringitubo
13	093.045.00	1	Rubinetto benzina
14	167.018.13	6	Fascetta tubo benzina
15	180.010.50	1	Tubo benzina Ø 5
16	180.003.60	1	Tubo benzina Ø 4
17	185.012.00	2	Dado fulcro bilanciere
18	190.020.13	2	Perno supporto motore
19	147.080.13	1	Molla tubo benzina
20	185.011.00	1	Dado fulcro motore
21	080.010.00	2	Portamolla
22	147.106.14	2	Molla antivibrazione
23	174.020.99	1	Attacco motore completo
24	190.019.13	1	Perno motore
25	147.109.13	1	Molla cavalletto doppia

Nr.	Code	Q.ty	Description
1	156.071.99	1	Frame
2	071.441.03	1	Oil tank cap cover
3	071.442.03	1	Fuel tank cap cover
4	071.144.00	1	Oil tank cap
5	092.016.03	1	Fuel tank cap
6	069.014.00	1	Oil tank
7	161.060.00	1	Petrol tank
8	094.007.00	1	Oil pipe connector
9	180.003.54	1	Oil pipe
10	147.102.13	1	Oil pipe spring
11	072.066.03	2	Rubber grommet
12	167.031.00	1	Clamp
13	093.045.00	1	Fuel cock
14	167.018.13	6	Petrol pipe clamp
15	180.010.50	1	Fuel hose Ø 5
16	180.003.60	1	Fuel hose Ø 4
17	185.012.00	2	Engine mount fixing nut
18	190.020.13	2	Engine mount bolt
19	147.080.13	1	Pipe spring
20	185.011.00	1	Lower engine mount nut
21	080.010.00	2	Full bump spring cup
22	147.106.14	2	Full bump spring
23	174.020.99	1	Engine mount bracket
24	190.019.13	1	Lower engine mount bolt
25	147.109.13	1	Main stand spring

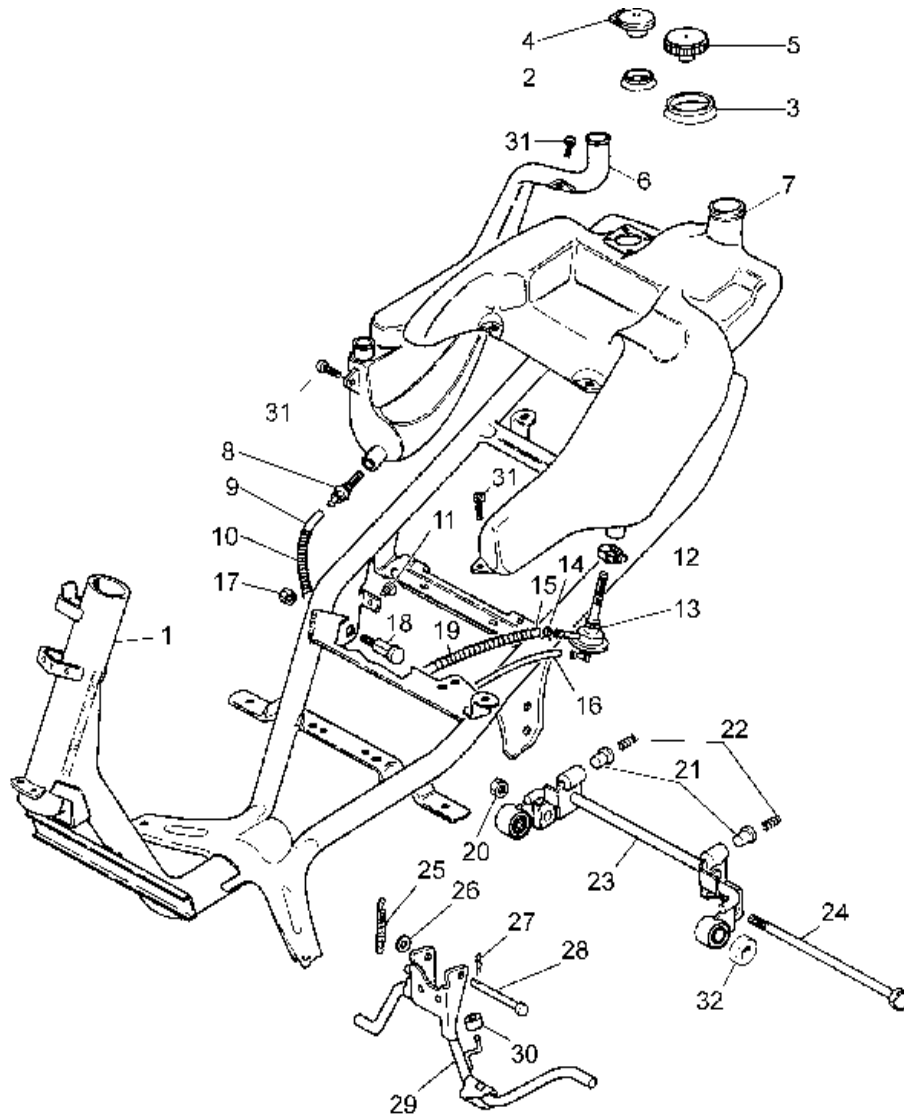

Nr.	Codice	Q.tà	Descrizione
26	071.140.03	1	Rondella in gomma
27	184.011.00	1	Copiglia
28	150.177.15	1	Perno cavalletto
29	158.040.99	1	Cavalletto completo
30	072.064.00	1	Gommino paracolpi cavalletto
31	184.060.15	3	Viti fissaggio serbatoio
32	191.025.13	1	Scodellino
--	090.028.00	1	Kit serrature

Nr.	Code	Q.ty	Description
26	071.140.03	1	Main stand washer
27	184.011.00	1	Split pin
28	150.177.15	1	Main stand pivot pin
29	158.040.99	1	Main stand assy
30	072.064.00	1	Main stand bump stop
31	184.060.15	3	Fuel tank fixing screw
32	191.025.13	1	Cap
--	090.028.00	1	Lock set

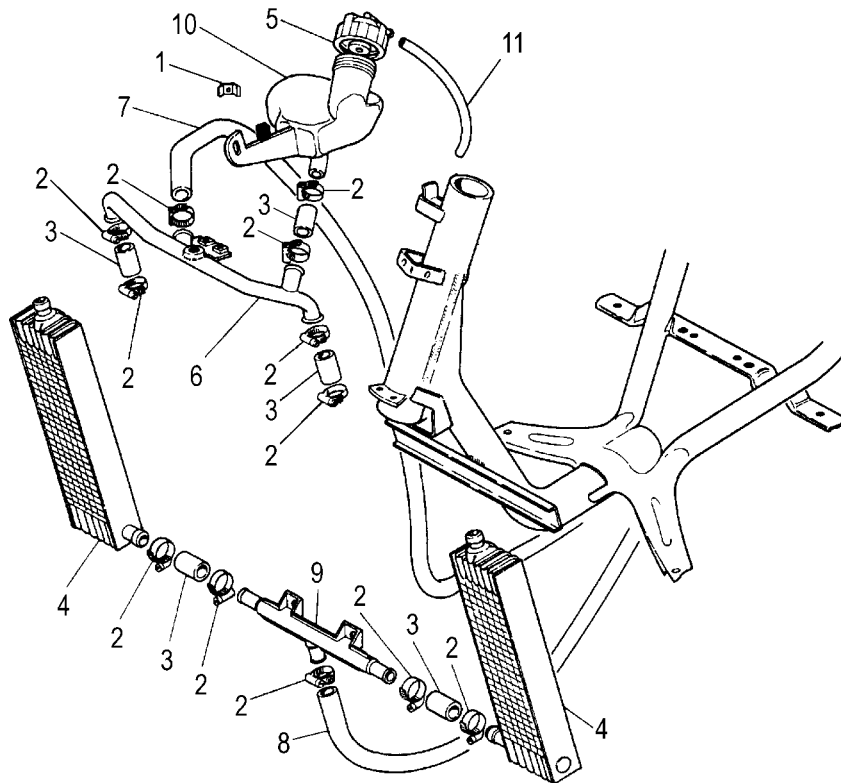

Nr.	Codice	Q.tà	Descrizione
1	191.022.13	1	Piastra attacco vaso espansione
2	167.031.00	12	Fascetta stringitubo
3	077.023.00	5	Manicotto radiatore
4	108.015.00	2	Radiatore
5	071.219.03	1	Tappo vaso espansione
6	077.026.13	1	Tubo mandata raccordo-radiatori
7	077.024.00	1	Tubo mandata motore-raccordo
8	077.029.00	1	Tubo ritorno raccordo-motore
9	077.027.13	1	Tubo ritorno radiatori-raccordo
10	108.016.00	1	Vaso espansione
11	180.002.54	1	Tubo sfiato vaso espansione

Nr.	Code	Q.ty	Description
1	191.022.13	1	Radiator filler neck fix bracket
2	167.031.00	12	Clip
3	077.023.00	5	Water pipe
4	108.015.00	2	Radiator
5	071.219.03	1	Radiator filler cap
6	077.026.13	1	Water delivery pipe
7	077.024.00	1	Water delivery pipe
8	077.029.00	1	Tube
9	077.027.13	1	Tube
10	108.016.00	1	Water tank
11	180.002.54	1	Hose

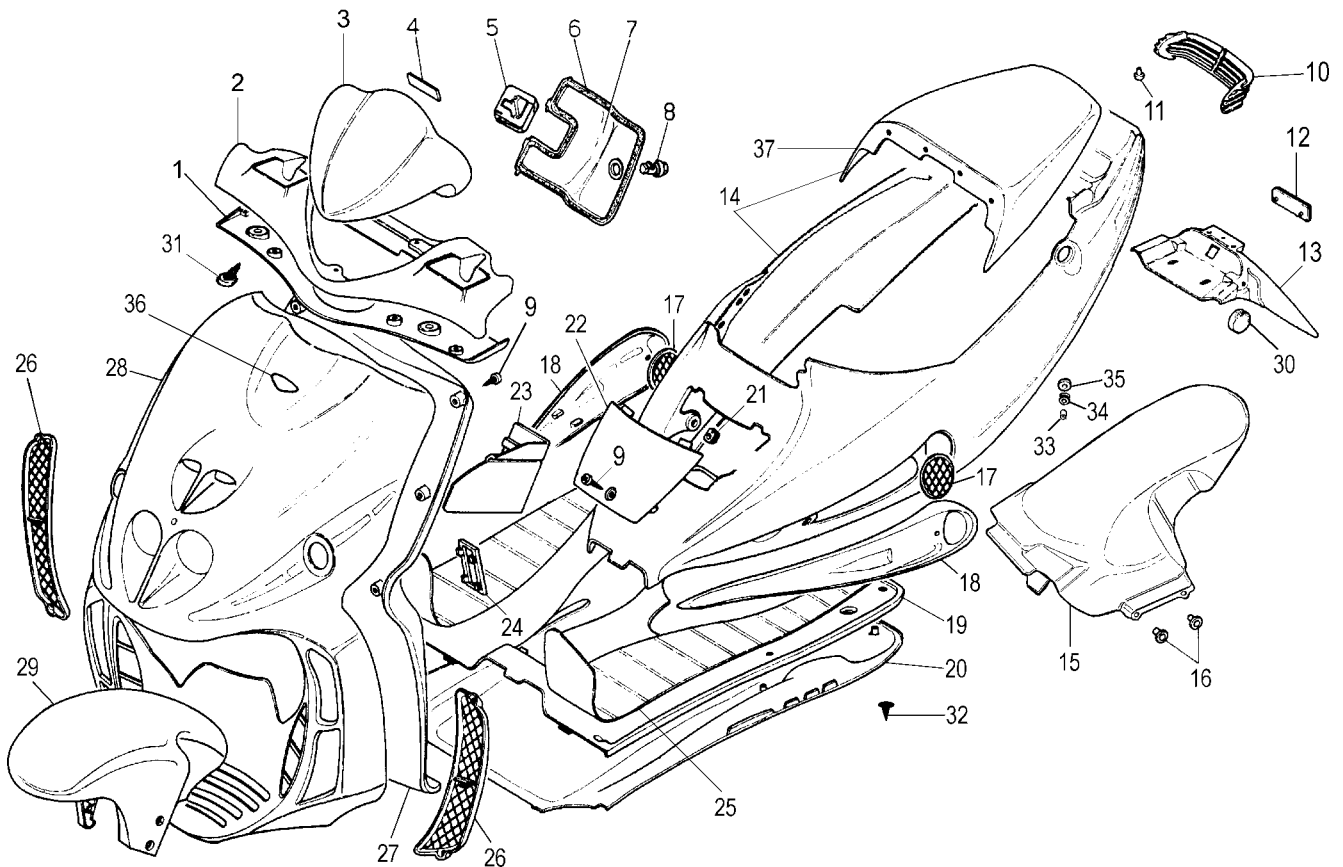

Nr.	Codice	Q.tà	Descrizione
1	071.184.03	1	Coprimanubrio inferiore
2	071.291. - -	1	Coprimanubrio superiore *
3	067.024.03	1	Portastrumenti
4	181.090.00	1	Etichetta in resina
5	071.182.03	1	Gancio borsa
6	072.067.00	1	Guarnizione coperchio batteria
7	071.185.03	1	Coperchio bauletto
8	090.024.00	1	Serratura sportello batteria
9	184.041.15	16	Viti per scudo paragambe
10	071.443.03	1	Griglia fanalino posteriore
11	071.152.03	4	Paracolpi
12	071.322.00	1	Catadiottro
13	057.055.03	1	Codino parafango
14	063.210. - -	1	Carena posteriore con codino *
15	056.058.07	1	Copri ruota posteriore
16	150.148.14	2	Boccola
17	071.192.03	1	Kit griglia carena
18	071.444.03	1	Prese d'aria in coppia
19	064.012.03	1	Pedana in plastica
20	063.102. - -	1	Puntone *
21	184.007.00	14	Clips per viti
22	071.186.03	1	Coperchio carena
23	071.187.03	1	Coperchio batteria

* Vedi tav. N° OO Colori

Nr.	Code	Q.ty	Description
1	071.184.03	1	Handlebar cover (lower)
2	071.291. - -	1	Handlebar cover (upper) *
3	067.024.03	1	Clocks top cover
4	181.090.00	1	Dashboard label
5	071.182.03	1	Bag handle
6	072.067.00	1	Battery cover gasket
7	071.185.03	1	Glove box cover
8	090.024.00	1	Glove box lock
9	184.041.15	16	Fairing screw
10	071.443.03	1	Rear lens grille
11	071.152.03	4	Screw
12	071.322.00	1	Red reflector
13	057.055.03	1	Rear mudguard tail
14	063.210. - -	1	Rear fairing with seat tail *
15	056.058.07	1	Rear mudguard
16	150.148.14	2	Rear hugger fixing bolts
17	071.192.03	1	Grill set
18	071.444.03	1	Air intake grilles
19	064.012.03	1	Foot board panel
20	063.102. - -	1	Belly pan *
21	184.007.00	14	Fairing fixing clips
22	071.186.03	1	Inspection cover
23	071.187.03	1	Battery cover

* Refer to N° OO Colour table

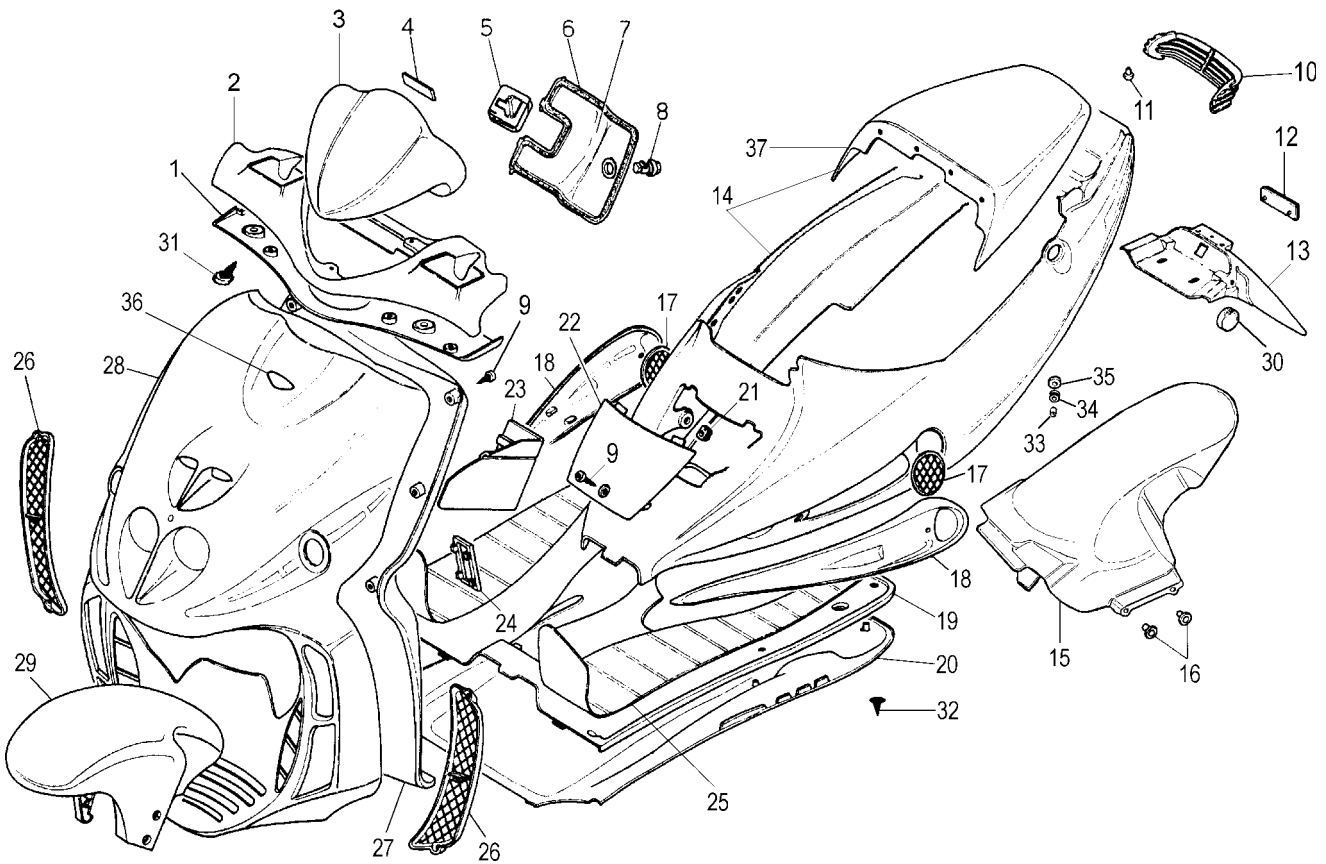

Nr.	Codice	Q.tà	Descrizione
24	071.145.03	1	Coperchio per numeri
25	064.013.07	1	Pedana in gomma in coppia
26	071.192.03	1	Kit griglie scudo
27	065.045.03	1	Paragambe
28	066.085. --	1	Scudo anteriore *
29	055.058. --	1	Parafango anteriore *
30	071.225.00	2	Catadiottro ambra
31	184.071.15	4	Viti autofilettante coprimanubrio
32	184.155.15	6	Vite pedana - carena
33	150.043.00	2	Distanziale
34	080.002.07	2	Gommino
35	072.087.00	4	Rondella speciale
36	181.338. --	1	Marca scudo
37	063.217. --	1	Codino sella *

Nr.	Code	Q.ty	Description
24	071.145.03	1	VIN numbers inspection cover
25	064.013.07	1	Mat set
26	071.192.03	1	Grille set
27	065.045.03	1	Front inner shield
28	066.085. --	1	Front shield *
29	055.058. --	1	Front mudguard *
30	071.225.00	2	Amber reflector
31	184.071.15	4	Handlebar cover screw
32	184.155.15	6	Footboard bolt
33	150.043.00	2	Spacer
34	080.002.07	2	Grommet
35	072.087.00	4	Washer
36	181.338. --	1	Front shield label
37	063.217. --	1	Seat back *

* Vedi tav. N° OO Colori

* Refer to N° OO Colour table

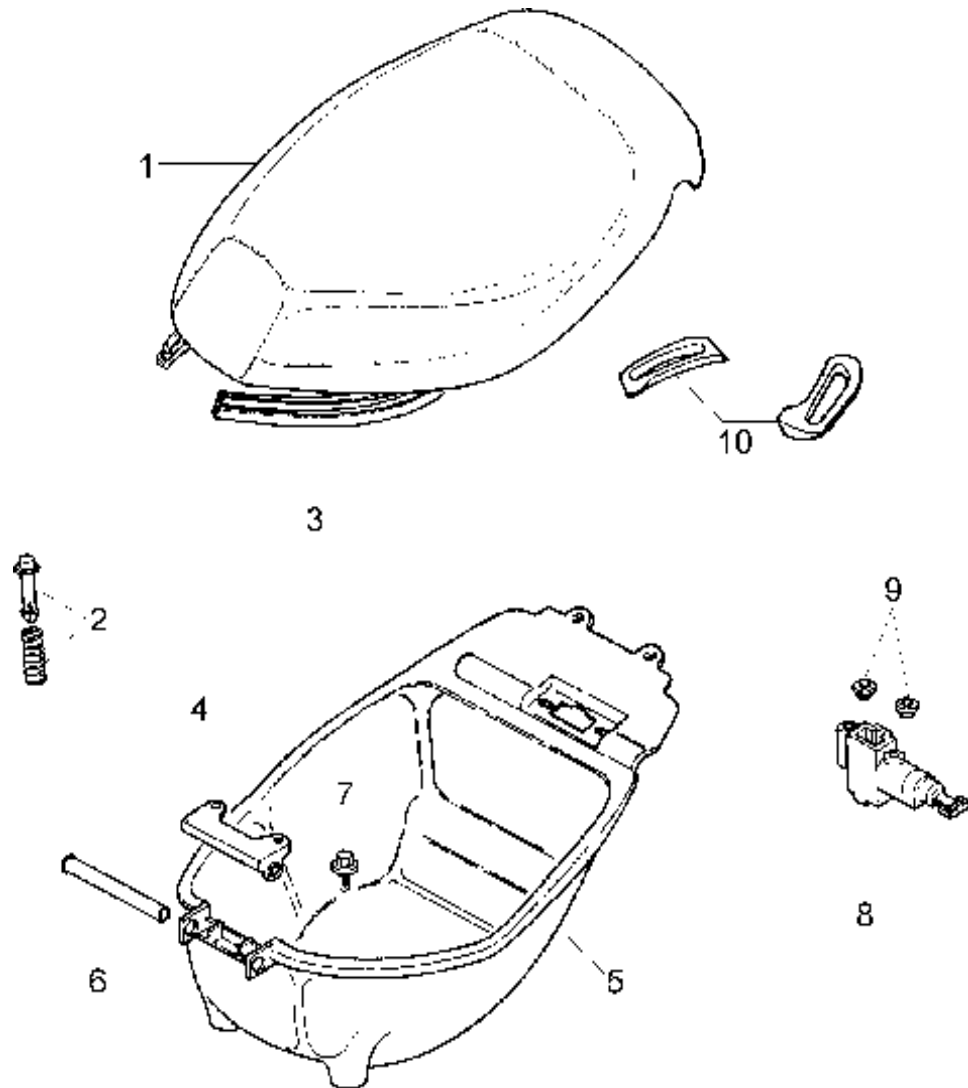

Nr.	Codice	Q.tà	Descrizione
1	106.092.03	1	Sellone
2	071.373.00	1	Push-up apertura sella
3	072.061.03	1	Guarnizione sella
4	188.040.99	1	Supporto sella
5	065.083.03	1	Vano portacasco
6	150.174.13	1	Tubo fulcro sella
7	190.022.00	4	Vite fissaggio vano porta casco
8	090.047.00	1	Serratura sella
9	150.148.14	2	Boccola
10	063.216.03	1	Cp. maniglie sella

Nr.	Code	Q.ty	Description
1	106.092.03	1	Seat
2	071.373.00	1	Seat push-up
3	072.061.03	1	Seat base seal
4	188.040.99	1	Seat hinge bracket
5	065.083.03	1	Helmet case
6	150.174.13	1	Seat hinge pin
7	190.022.00	4	Fixing bolt
8	090.047.00	1	Seat lock
9	150.148.14	2	Fixing bolt set
10	063.216.03	1	Handgrip set

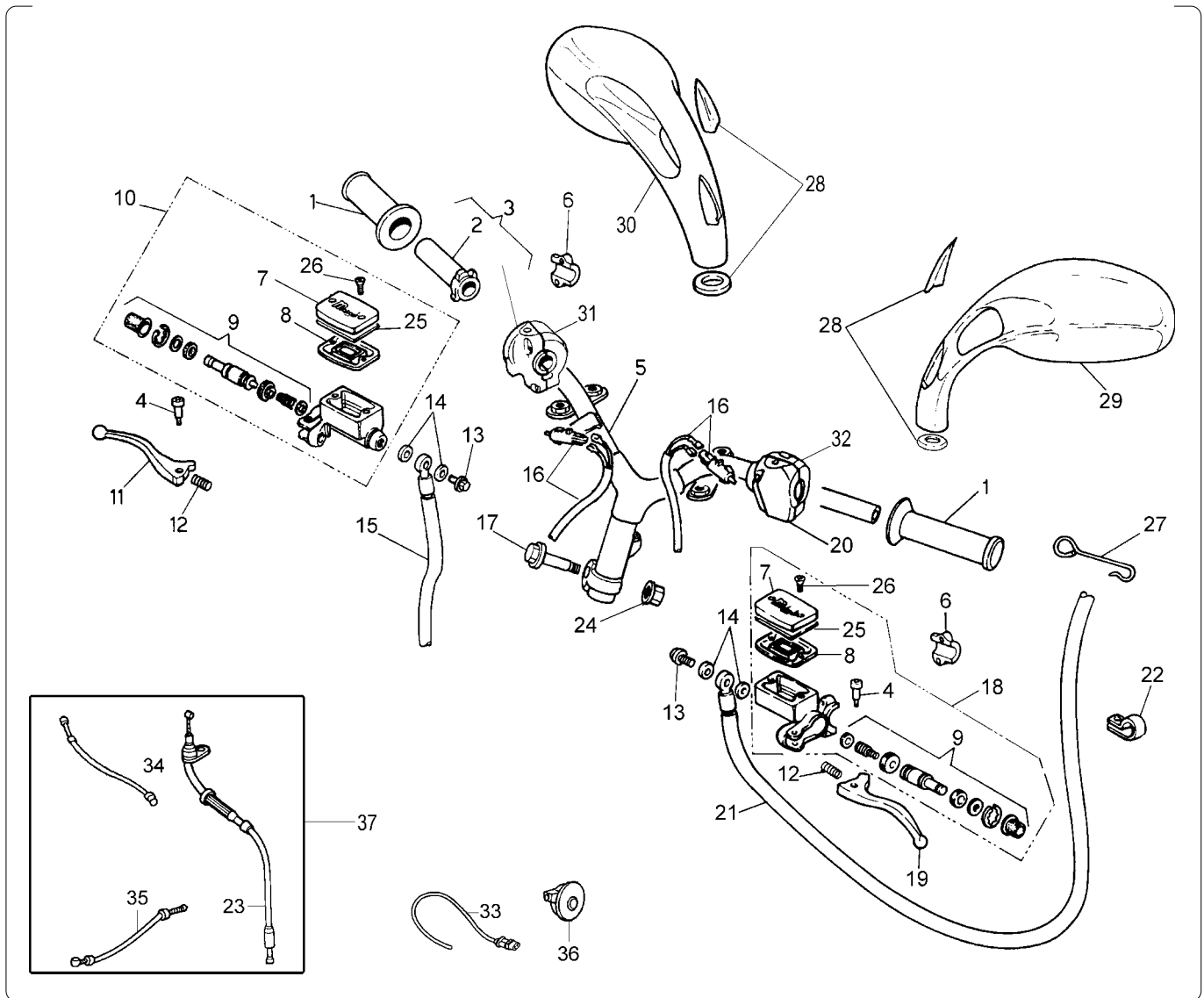

Nr.	Codice	Q.tà	Descrizione
1	097.014.03	1	Kit manopole (dx + sx)
2	121.134.00	1	Tubo comando gas
3	028.018.00	1	Comando gas completo
4	121.106.00	2	Fulcro leva dx
5	162.032.13	1	Manubrio
6	121.139.00	2	Attacco pompa
7	121.127.00	2	Coperchio pompa
8	121.099.00	2	Guarnizione pompa
9	121.128.00	2	Pistone completo
10	030.016.03	1	Pompa freno anteriore
11	121.132.03	1	Leva dx
12	121.108.00	2	Molla leva freno
13	150.024.14	2	Vite trasmissione idraulica
14	190.006.00	4	Rasamento
15	033.035.00	1	Trasmissione idraulica anteriore
16	017.140.00	2	Cablaggio interruttore stop
17	150.179.13	1	Vite fissaggio manubrio
18	030.020.03	1	Pompa freno posteriore
19	121.142.03	1	Leva sx
20	125.031.00	1	Comando sx completo
21	033.033.00	1	Trasmissione idraulica posteriore
22	167.038.00	1	Fascetta trasmissione idraulica
23	NONFORNIBILE		
24	184.056.13	1	Dado fissaggio manubrio

Nr.	Code	Q.ty	Description
1	097.014.03	1	Handgrip set (r/h+l/h)
2	121.134.00	1	Throttle twist grip tube
3	028.018.00	1	Twist grip tube & bracket
4	121.106.00	2	R/h lever bolt
5	162.032.13	1	Handlebar
6	121.139.00	2	Front brake clamp
7	121.127.00	2	Cover
8	121.099.00	2	Master cylinder seal
9	121.128.00	2	Piston kit
10	030.016.03	1	Master cylinder assy
11	121.132.03	1	R/h brake lever
12	121.108.00	2	R/h brake lever spring
13	150.024.14	2	Banjo bolt
14	190.006.00	4	Copper banjo washer
15	033.035.00	1	Front brake hose
16	017.140.00	2	Brake light switch & wire
17	150.179.13	1	Clamp bolt
18	030.020.03	1	Rear brake pump
19	121.142.03	1	L/h brake lever
20	125.031.00	1	Rear brake control assy (l/h)
21	033.033.00	1	Rear brake hose
22	167.038.00	1	Rear brake hose clamp
23	NOTAVAILABLE		
24	184.056.13	1	Handlebar fixing clamp nut

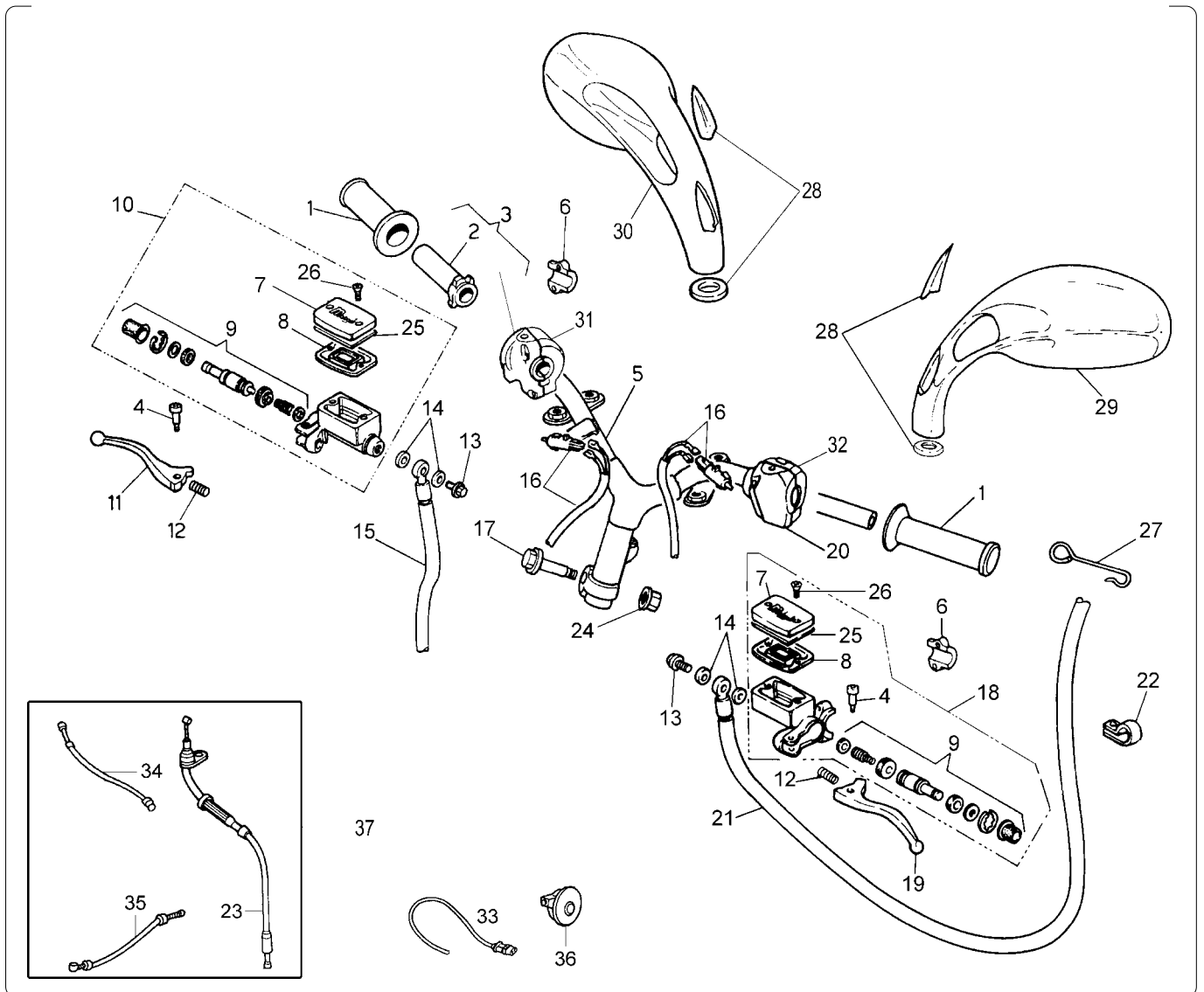

Nr.	Codice	Q.tà	Descrizione
25	121.141.00	2	Scodellino coperchio pompa
26	184.179.00	4	Vite coperchio pompa
27	147.113.13	1	Molla trasmissione idraulica
28	071.254.03	2	Kit tappo specchio
29	088.018. - -	1	Specchio sx *
30	088.019. - -	1	Specchio dx * (di serie mercato estero)
31	020.047.00	1	Commutatore dx
32	020.045.00	1	Commutatore sx con MODE
33	024.073.00	1	Sensore TPS
34	NONFORNIBILE		
35	NONFORNIBILE		
36	178.157.00	1	Rinvio sensore TPS
37	034.157.03	1	Kit trasmissioni gas

Nr.	Code	Q.ty	Description
25	121.141.00	2	Master cylinder cover seal
26	184.179.00	4	Brake pump cover screw
27	147.113.13	1	Spring
28	071.254.03	2	Mirror rubber & washer set
29	088.018. - -	1	L/h mirror *
30	088.019. - -	1	R/h mirror * (originally fitted)
31	020.047.00	1	R/h switch
32	020.045.00	1	L/h switch with MODE control
33	024.073.00	1	TPS sensor
34	NOT AVAILABLE		
35	NOT AVAILABLE		
36	178.157.00	1	TPS sensor gear
37	034.157.03	1	Throttle cables kit

* Vedi Tav. OO Colori

* Refer to N° OO Colour table

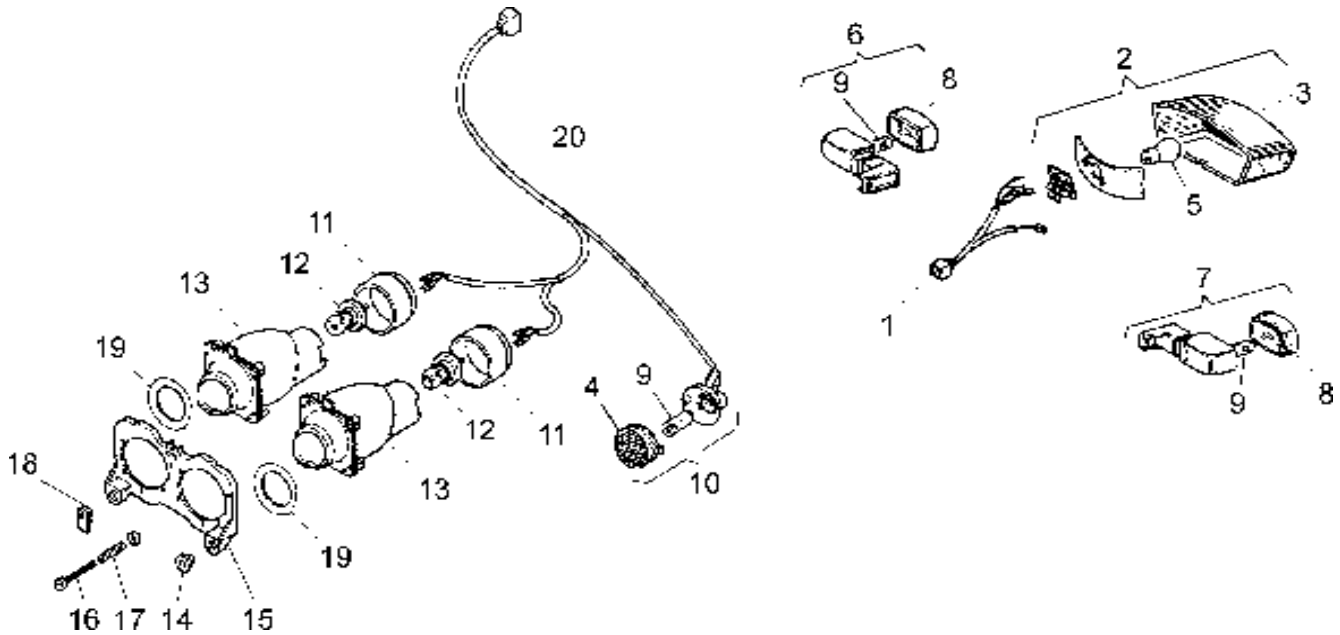

Nr.	Codice	Q.tà	Descrizione
1	017.195.00	1	Cablaggio fanale posteriore
2	016.066.00	1	Fanale posteriore
3	016.069.00	1	Vetro fanale posteriore
4	019.039.00	2	Vetro indicatori anteriore
5	022.048.00	1	Lampadina 12 V - 5-21 W
6	019.075.00	1	Indicatore posteriore dx
7	019.076.00	1	Indicatore posteriore sx
8	019.077.00	2	Vetro indicatori posteriore
9	022.017.00	4	Lampadina 12 V - 10 W
10	019.034.00	2	Indicatori anteriori sx - dx
11	072.069.00	2	Cappuccio faro
12	022.042.00	2	Lampadina 12 V - 15 W
13	015.051.00	2	Faro anteriore
14	075.010.00	2	Gommino supporto faro
15	071.194.03	1	Supporto faro anteriore
16	190.004.00	1	Vite regolazione faro
17	147.038.14	1	Molla regolazione faro
18	191.017.13	1	Piastrina regolazione faro
19	071.445.16	2	Anello adattatore faro anteriore
20	017.248.00	1	Cablaggio faro anteriore

Nr.	Code	Q.ty	Description
1	017.195.00	1	Rear light wiring harness
2	016.066.00	1	Rear light assembly
3	016.069.00	1	Rear light lens
4	019.039.00	2	Front indicators lens
5	022.048.00	1	12 V - 5-21 W bulb
6	019.075.00	1	R/h rear indicator
7	019.076.00	1	L/h rear indicator
8	019.077.00	2	Rear indicators lens
9	022.017.00	4	12 V - 10 W bulb
10	019.034.00	2	L/h+r/h front indicators
11	072.069.00	2	Headlamp rubber cap
12	022.042.00	2	12 V - 15 W bulb
13	015.051.00	2	Head light assy
14	075.010.00	2	Head lamp bracket grommet
15	071.194.03	1	Head lamp bracket
16	190.004.00	1	Head lamp adjusting screw
17	147.038.14	1	Head lamp adjusting spring
18	191.017.13	1	Head lamp adjusting plate
19	071.445.16	2	Head lamp adapter ring
20	017.248.00	1	Head lamp wiring harness

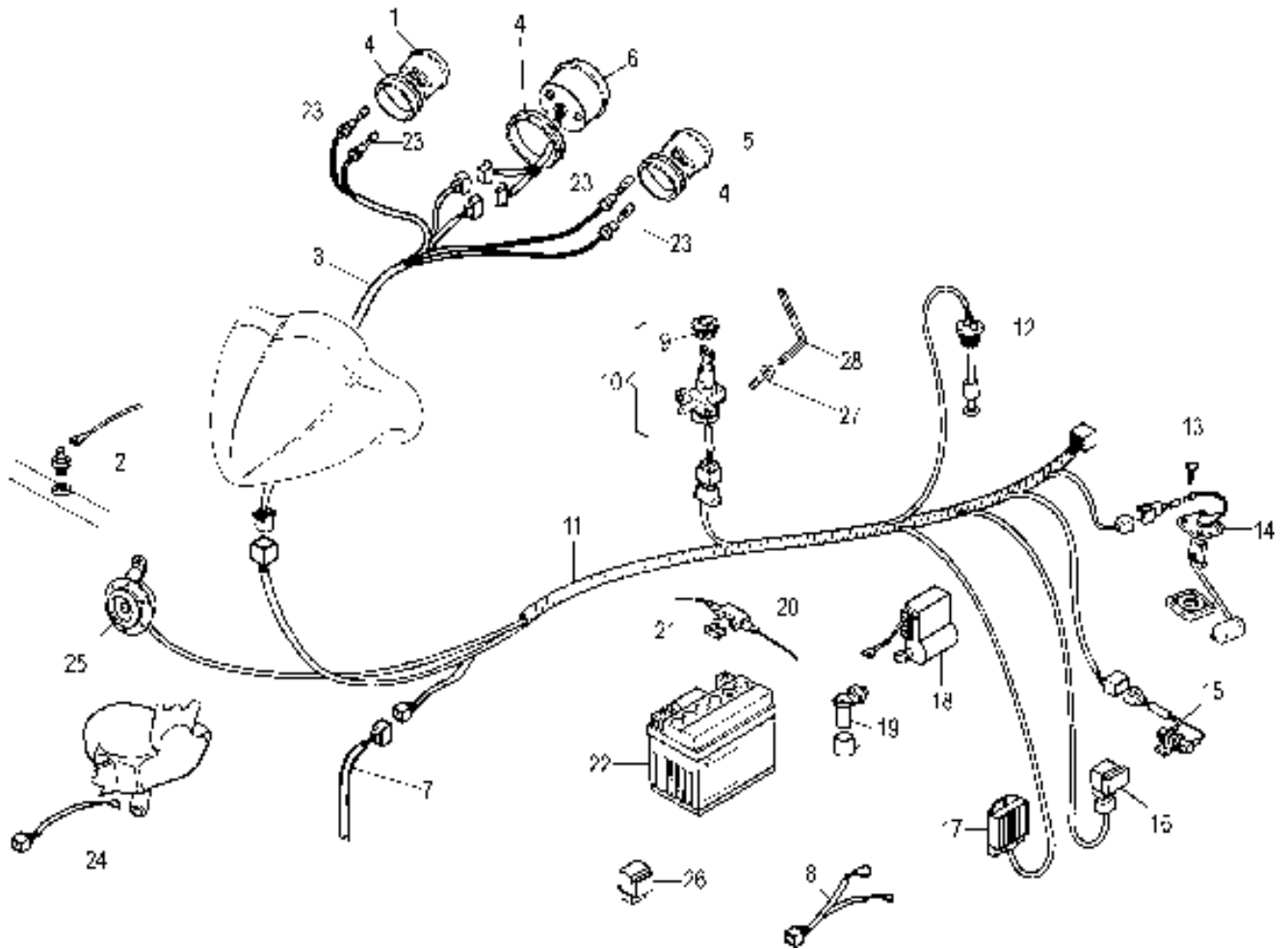

Nr.	Codice	Q.tà	Descrizione
1	178.155.00	1	Orologio spie liquido + luci
2	021.013.00	1	Sonda temperatura acqua
3	017.310.00	1	Cablaggio cruscotto
4	072.059.00	1	Guarnizioni orologi in coppia
5	178.156.00	1	Orologio spie olio + indicatori
6	178.154.00	1	Orologio contakm digit
7	178.129.00	1	Trasmissione contakm digit
8	017.226.00	1	Cablaggio batteria
9	071.163.00	1	Ghiera serratura avviamento
10	090.031.00	1	Serratura avviamento
11	017.312.00	1	Cablaggio centrale
12	093.051.00	1	Sonda livello olio
13	184.009.00	4	Viti fissaggio sonda benzina
14	093.046.00	1	Sonda livello benzina
15	025.014.00	1	Resistenza
16	025.015.00	1	Relais
17	026.011.00	1	Regolatore di tensione
18	024.033.00	1	Centralina elettronica
19	073.007.00	1	Pipetta candela c/cappuccio
20	025.016.00	1	Portafusibile
21	025.010.00	1	Fusibile 10 A
22	074.004.00	1	Batteria 12 V - 4 Ah
23	022.036.00	2	Lampadina 12 V - 1,2 W
24	017.202.00	1	Cablaggio spia livello liquido
25	018.054.00	1	Avvisatore acustico

Nr.	Code	Q.ty	Description
1	178.155.00	1	Headlight & coolant indicator
2	021.013.00	1	Water temperature sender
3	017.310.00	1	Dashboard wiring
4	072.059.00	1	Gasket set
5	178.156.00	1	Oil mixer & indicators warning light
6	178.154.00	1	Digit speedometer
7	178.129.00	1	Digit speedocable
8	017.226.00	1	Battery loom
9	071.163.00	1	Ignition lock rim
10	090.031.00	1	Ignition barrel
11	017.312.00	1	Main wiring harness
12	093.051.00	1	Oil level gauge
13	184.009.00	4	Fixing screw
14	093.046.00	1	Fuel level gauge
15	025.014.00	1	Resistor
16	025.015.00	1	Relay
17	026.011.00	1	Regulator
18	024.033.00	1	CDI
19	073.007.00	1	Spark plug cap
20	025.016.00	1	Fuse holder
21	025.010.00	1	10 A fuse
22	074.004.00	1	12 V - 4 Ah battery
23	022.036.00	2	12 V - 1,2 W bulb
24	017.202.00	1	Coolant warning light wiring
25	018.054.00	1	Horn

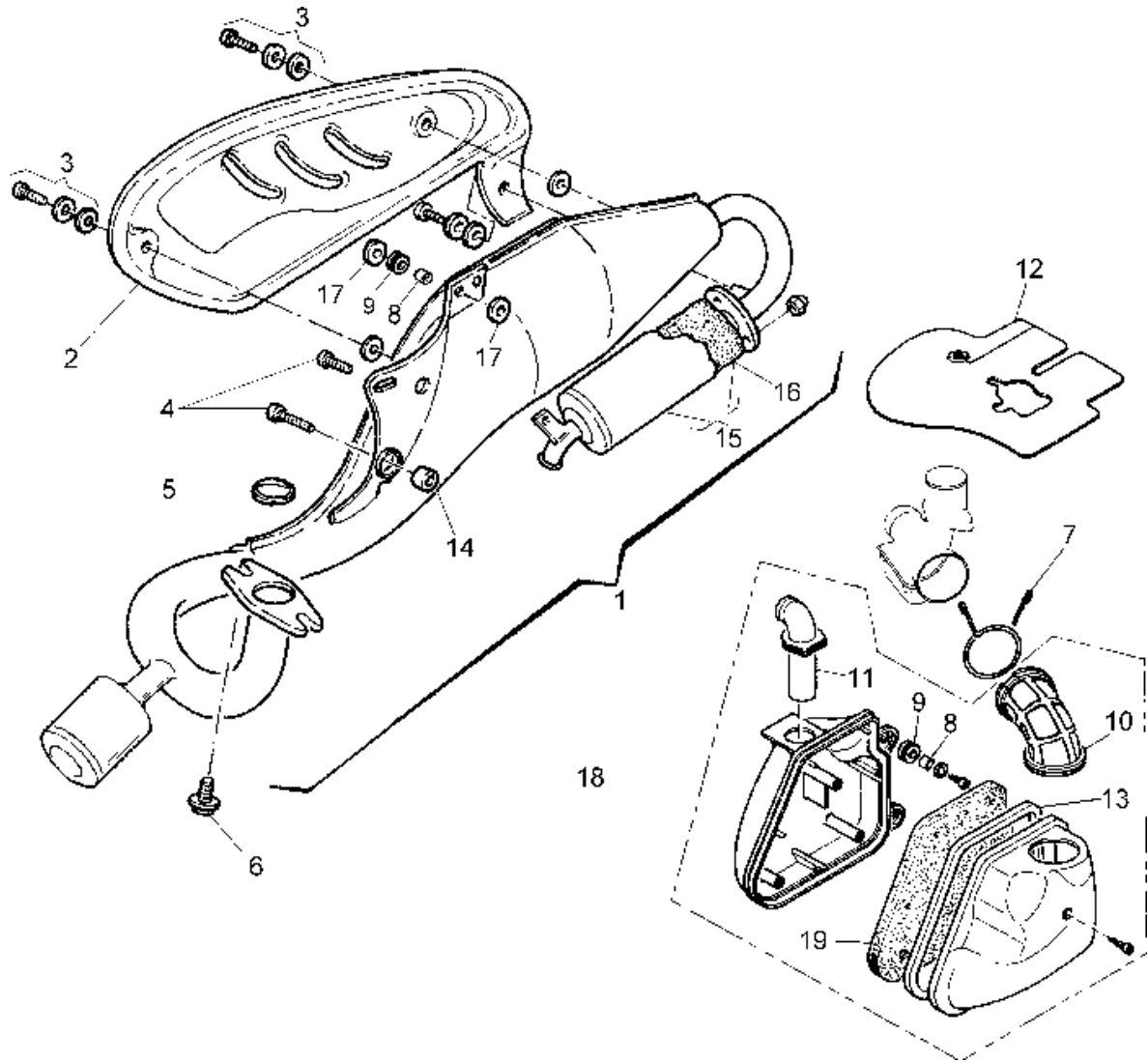

Nr.	Codice	Q.tà	Descrizione
1	165.146.99	1	Marmitta completa catalitica
2	071.341.03	1	Protezione marmitta
3	150.200.00	1	Kit viti fissaggio protezione
4	184.038.13	2	Vite fissaggio marmitta
5	072.053.00	1	Guarnizione scarico
6	184.006.00	2	Vite fissaggio marmitta
7	147.082.13	1	Molla manicotto aspirazione
8	150.043.00	4	Distanziale
9	080.002.07	4	Gommino
10	076.013.00	1	Manicotto aspirazione grande
11	076.012.00	1	Manicotto aspirazione piccolo
12	057.033.00	1	Bancalina carburatore
13	072.056.00	1	Guarnizione
14	075.024.00	1	Silentblock marmitta
15	166.042.08	1	Silenziatore completo kat
16	300.325.00	1	Filtro silenziatore
17	072.087.00	4	Rondella speciale
18	066.058.03	1	Cassetta filtro completa
19	066.045.00	1	Filtro aria

Nr.	Code	Q.ty	Description
1	165.146.99	1	Kat-exhaust assy
2	071.341.03	1	Heat shield
3	150.200.00	1	Fixing screws set
4	184.038.13	2	Exhaust fixing screw
5	072.053.00	1	Exhaust gasket
6	184.006.00	2	Exhaust fixing screw
7	147.082.13	1	Air box hose spring clip
8	150.043.00	4	Spacer
9	080.002.07	4	Grommet
10	076.013.00	1	Air box/carb. sleeve
11	076.012.00	1	Airbox intake sleeve
12	057.033.00	1	Carburettor cover
13	072.056.00	1	Gasket
14	075.024.00	1	Exhaust silentblock
15	166.042.08	1	Kat-silencer assy
16	300.325.00	1	Silencer filter
17	072.087.00	4	Washer
18	066.058.03	1	Air box complete
19	066.045.00	1	Air filter

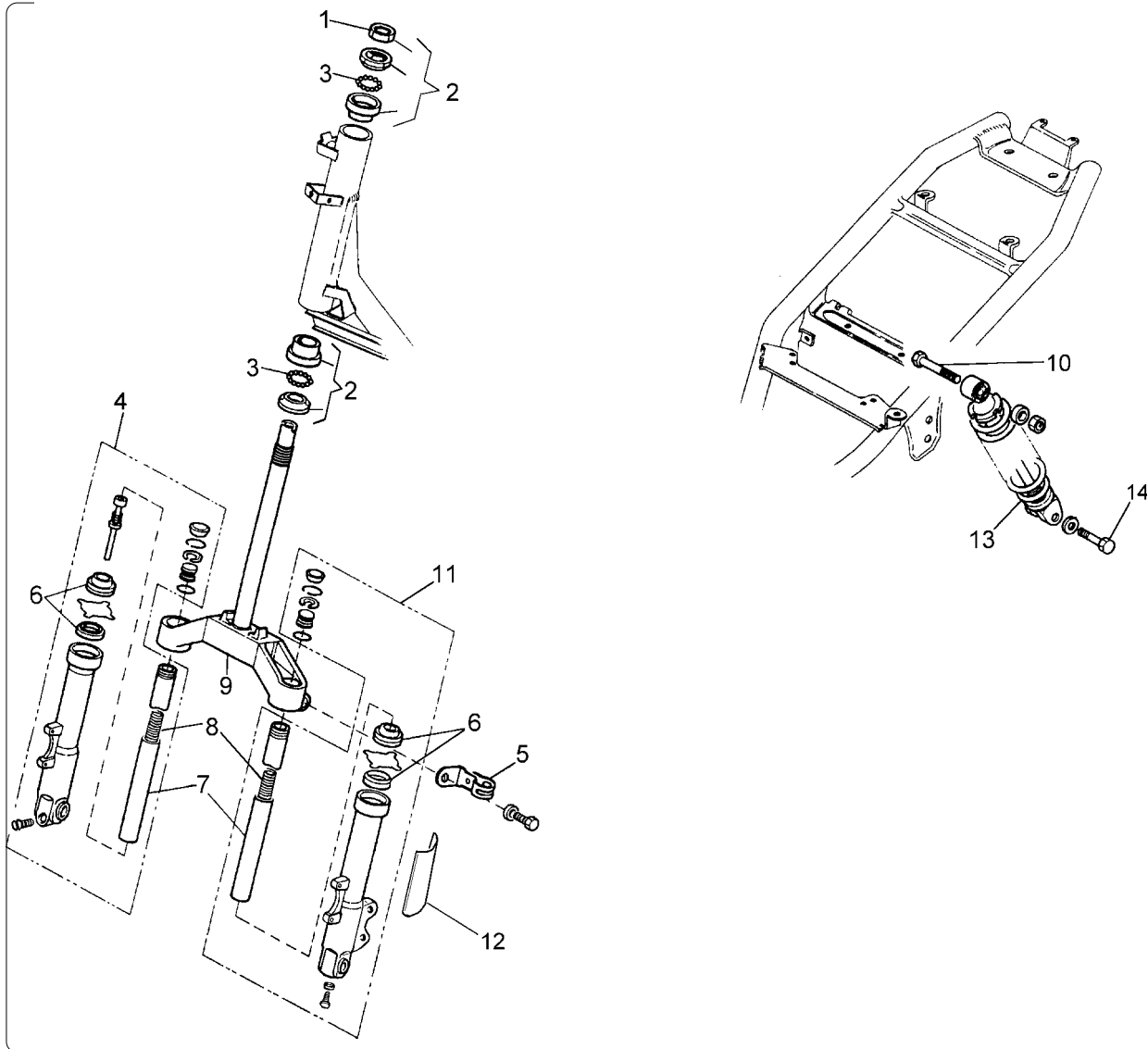

Nr.	Codice	Q.tà	Descrizione
1	185.009.13	1	Ghiera serie sterzo
2	104.017.00	1	Serie sterzo
3	120.261.00	48	Sfere
4	120.317.00	1	Portaruota completo dx
5	147.101.13	2	Molla trasmissione contakm
6	120.312.00	2	Kit parapolvere - paraolio - gommini
7	120.302.00	2	Canna dx + sx
8	120.305.00	2	Molla
9	120.301.99	1	Testa croce
10	184.033.13	1	Vite fissaggio ammortizzatore sup.
11	120.358.00	1	Portaruota completo sx
12	181.123.08	1	Etichetta adesiva foderi dx + sx
13	010.034.08	1	Ammortizzatore
14	184.038.13	1	Vite fissaggio ammortizzatore inf.
--	013.046.50	1	Forcella completa

Nr.	Code	Q.ty	Description
1	185.009.13	1	Steering head nut
2	104.017.00	1	Steering head cap set
3	120.261.00	48	Steering ball cages
4	120.317.00	1	R/h fork leg assy
5	147.101.13	2	Fork leg brake hose clip
6	120.312.00	2	Fork bush/oil seal
7	120.302.00	2	R/h-l/h tube
8	120.305.00	2	R/h-l/h tube spring
9	120.301.99	1	Bottom yoke
10	184.033.13	1	Fixing screw
11	120.358.00	1	L/h fork leg assy
12	181.123.08	1	Tube cover label
13	010.034.08	1	Rear shock absorber
14	184.038.13	1	Fixing screw
--	013.046.50	1	Front fork assy

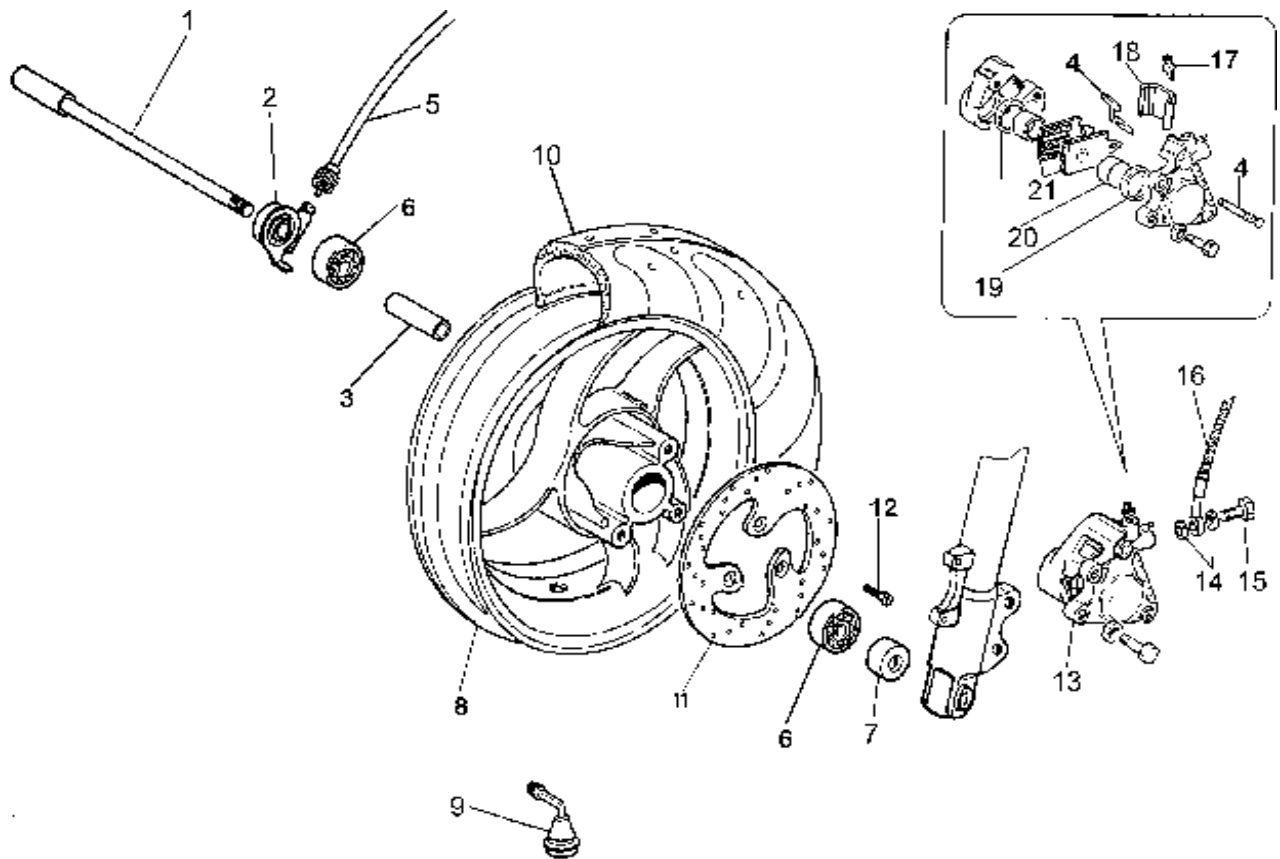

Nr.	Codice	Q.tà	Descrizione
1	119.443.00	1	Perno ruota
2	178.126.00	1	Rinvio kontakm digit
3	119.456.00	1	Distanziale interno
4	119.457.00	1	Kit perno + molla
5	178.129.00	1	Trasmissione kontakm digit
6	119.411.00	2	Cuscinetto
7	119.432.00	1	Distanziale
8	109.053. - -	1	Ruota anteriore tubeless *
9	094.008.00	1	Valvola tubeless
10	050.032.00	1	Copertura 120/70 - 12 tubeless
11	119.465.00	1	Disco freno
12	184.287.00	3	Vite fissaggio disco
13	031.019. - -	1	Pinza freno *
14	190.006.00	2	Rasamento
15	150.024.14	1	Vite trasmissione idraulica
16	033.035.00	1	Trasmissione idraulica
17	119.436.00	1	Vite spurgo
18	119.434.00	1	Cuffia
19	119.440.00	1	Serie anelli di tenuta
20	119.435.00	1	Pistone pinza
21	119.502.00	1	Pastiglie freno

* Specificare colore

Nr.	Code	Q.ty	Description
1	119.443.00	1	Front wheel spindle
2	178.126.00	1	Digit speedo drive
3	119.456.00	1	Spacer
4	119.457.00	1	Support pads set
5	178.129.00	1	Digit speedocable
6	119.411.00	2	Bearing
7	119.432.00	1	Spacer
8	109.053. - -	1	Tubeless front wheel *
9	094.008.00	1	Wheel valve
10	050.032.00	1	Tyre 120/70 - 12 tubeless
11	119.465.00	1	Front brake disc
12	184.287.00	3	Brake disc mounting screw
13	031.019. - -	1	Front brake caliper
14	190.006.00	2	Copper banjo washer
15	150.024.14	1	Banjo bolt
16	033.035.00	1	Front brake hose
17	119.436.00	1	Screw
18	119.434.00	1	Brake pad cover
19	119.440.00	1	Seal ring set
20	119.435.00	1	Front brake piston
21	119.502.00	1	Brake pads set

* To be completed with colour code

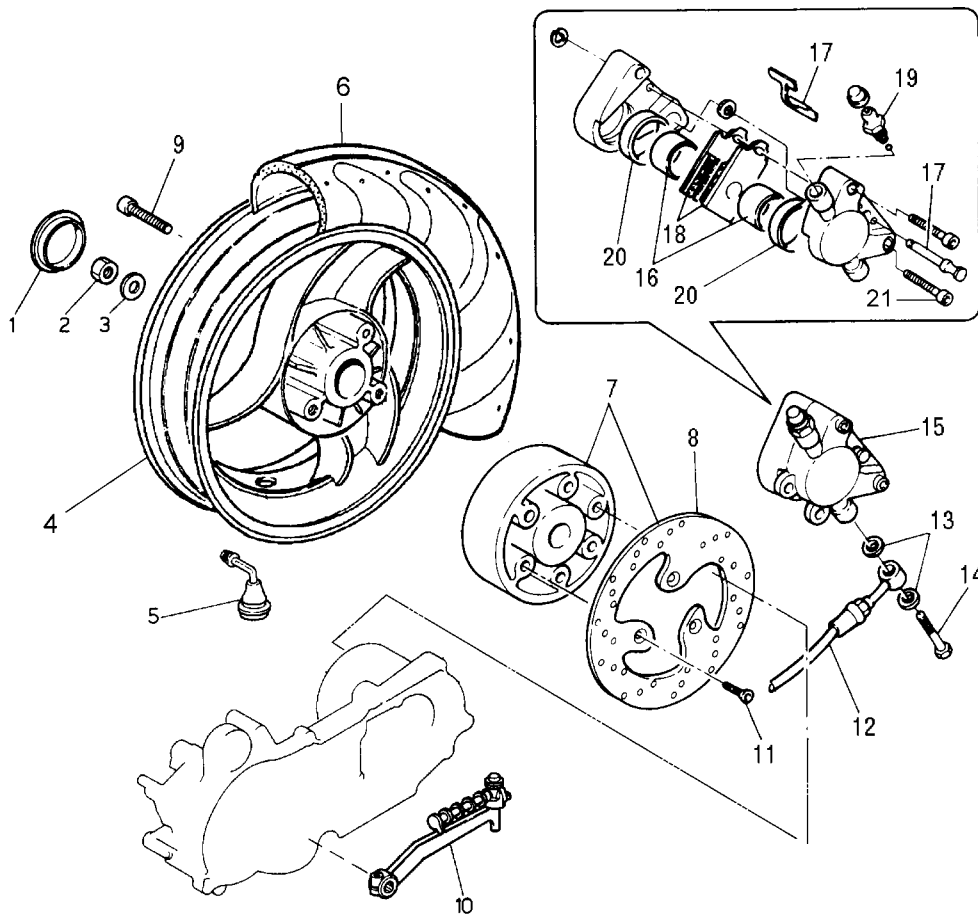
Ruota posteriore e impianto frenante
Rear wheel & brake system

Nr.	Codice	Q.tà	Descrizione
1	071.198.03	1	Tappo ruota
2	185.010.00	1	Dado ruota posteriore
3	119.224.00	1	Rondella
4	110.051. - -	1	Ruota posteriore tubeless *
5	094.008.00	1	Valvola tubeless
6	050.033.00	1	Copertura 130/70 - 12" tubeless
7	114.010.00	1	Mozzo completo di disco freno
8	119.430.00	1	Disco freno
9	184.166.13	3	Vite fissaggio ruota
10	081.009.03	1	Leva messa in moto
11	184.287.00	3	Vite fissaggio disco
12	033.033.00	1	Trasmissione idraulica
13	190.006.00	2	Rasamento
14	150.024.14	1	Vite trasmissione idraulica
15	031.022. - -	1	Pinza freno *
16	119.462.00	1	Kit pistoncini
17	119.459.00	1	Kit perno + molla
18	119.502.00	1	Pastiglie freno
19	119.279.00	1	Vite spurgo
20	119.460.00	1	Kit anelli di tenuta
21	184.248.01	2	Viti unione corpo pinza

Nr.	Code	Q.ty	Description
1	071.198.03	1	Hub cap
2	185.010.00	1	Rear wheel nut
3	119.224.00	1	Washer
4	110.051. - -	1	Tubeless rear wheel assy *
5	094.008.00	1	Wheel valve
6	050.033.00	1	Tyre 130/70 - 12" tubeless
7	114.010.00	1	Rear hub assy
8	119.430.00	1	Disc brake
9	184.166.13	3	Wheel fixing screw
10	081.009.03	1	Kick starter lever
11	184.287.00	3	Disc brake fixing screw
12	033.033.00	1	Brake hose
13	190.006.00	2	Copper banjo washer
14	150.024.14	1	Brake hose screw
15	031.022. - -	1	Rear disc caliper *
16	119.462.00	1	Piston kit
17	119.459.00	1	Bolt & clip set
18	119.502.00	1	Brake pads
19	119.279.00	1	Screw
20	119.460.00	1	Seal ring set
21	184.248.01	2	Screw

* Specificare colore

*To be completed with colour code



TABELLA COLORI - COLOUR CODES

Colori - Colours

N° Nr.	Codice Code	50 BluNotte-Titanio DarkB.-Titanium	55 Spectrum Spectrum	59 Rosso Corsa Racing Red	70 Giallo Yellow	87 Argento Lucido Bright Silver	98 Titanio Titanium		
1	055.058.	98	93	59	70	87	98		
2	063.102.	98	55	71	70	87	98		
3	063.210.	94	55	59	70	87	98		
4	066.085.	50	55	59	70	87	98		
5	071.291.	94	58	71	70	87	98		
6 A	088.018.	94	58	71	70	87	98		
6 B	088.019.	94	58	71	70	87	98		
7	063.217.	94	93	59	70	87	98		
--	181.303.	01	--	00	00	01	01		
--	181.322.	--	00	--	--	--	--		

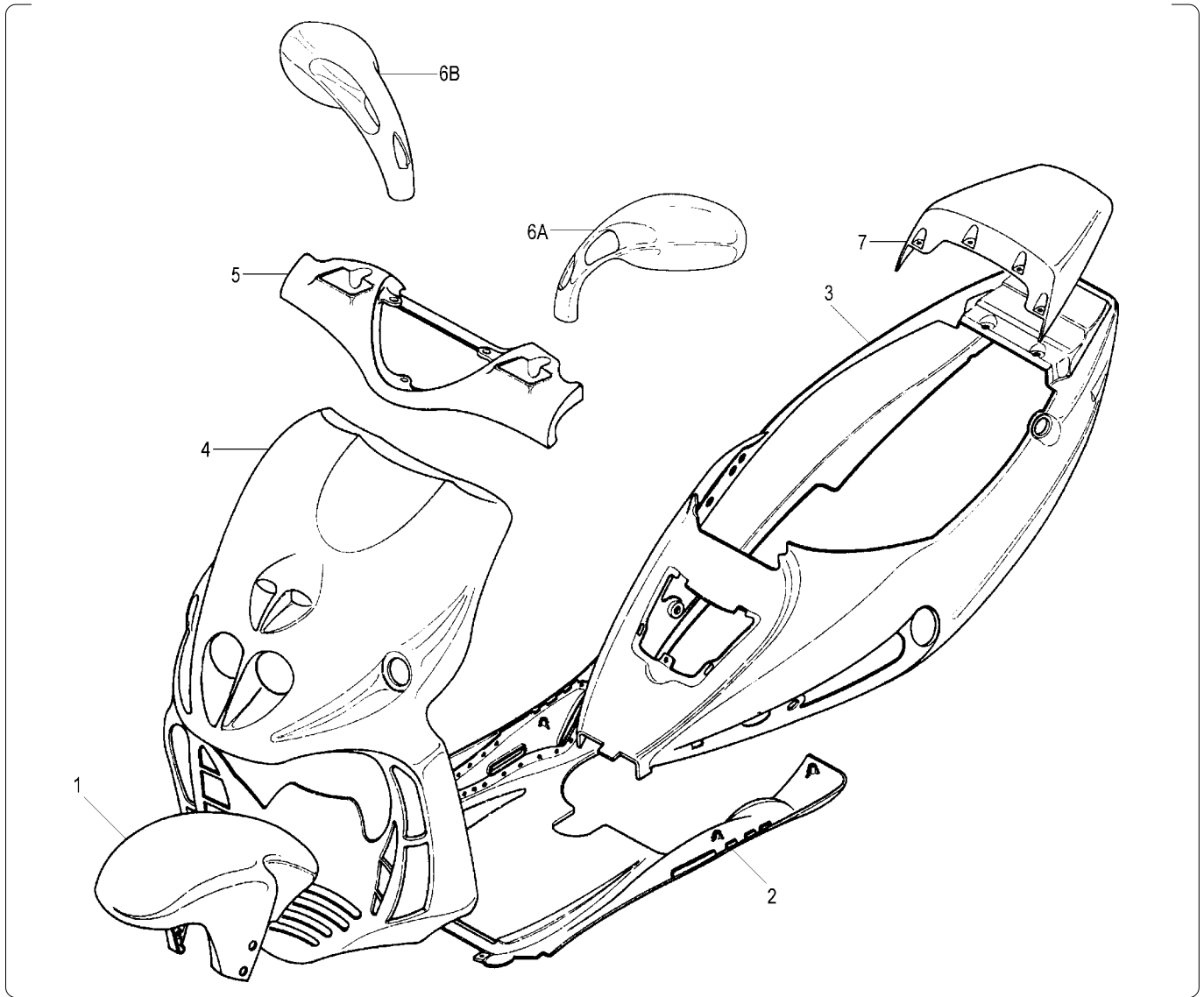
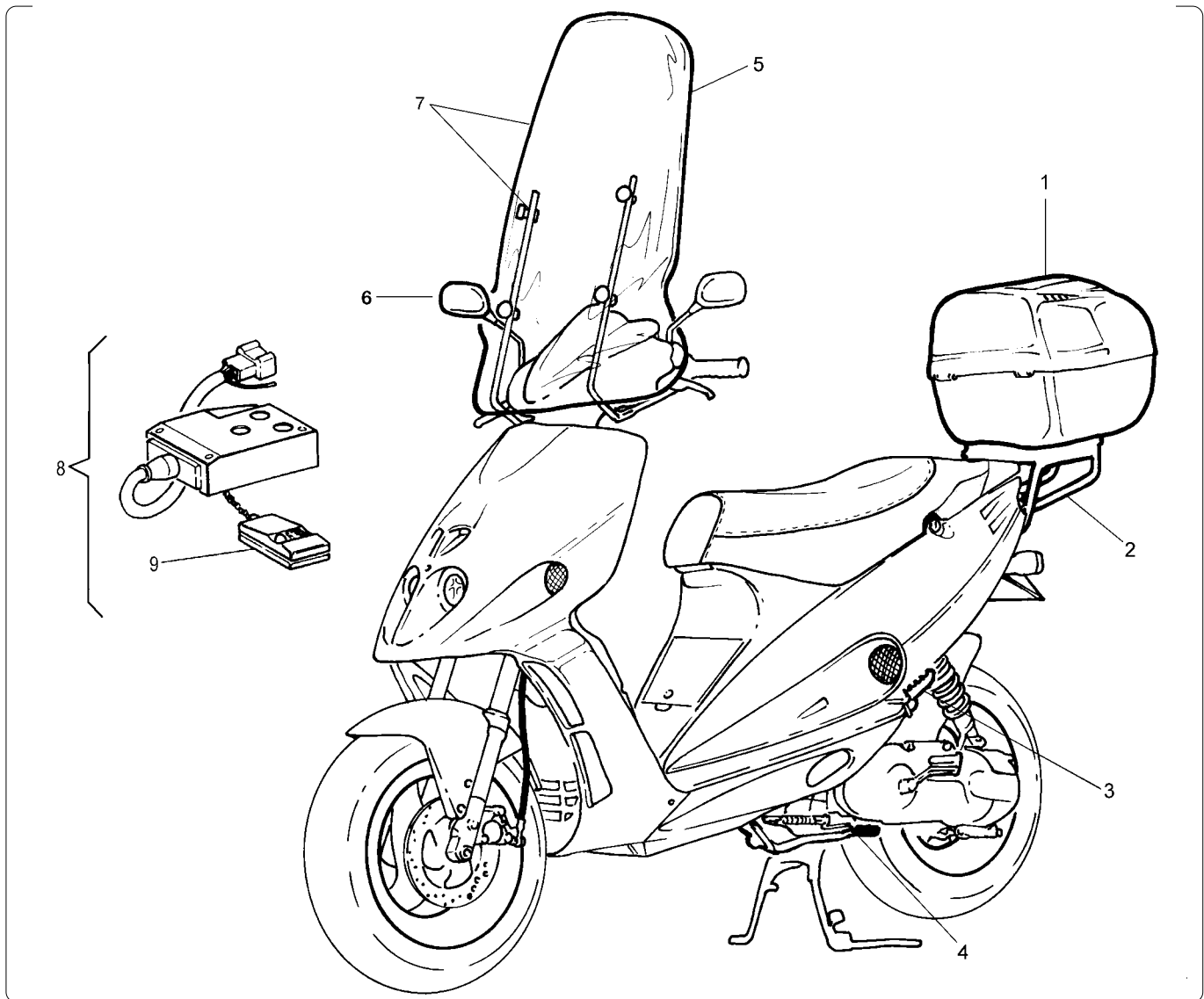

Nr.	Codice	Q.tà	Descrizione
1	065.072.03	1	Baulone porta casco
2	173.048.00	1	Portapacco completo
3	084.033.00	1	Staffe poggiapiedi
4	159.034.99	1	Cavalletto laterale
5	063.145.00	1	Lastra parabrezza
6	088.019. --	1	Specchio dx * (di serie mercato estero)
7	063.108.00	1	Parabrezza completo
8	018.078.00	1	Antifurto elettronico
9	018.079.00	1	Radiocomando
--	065.027.00	1	Coprimoto scooter standard
--	065.077.00	1	Coprimoto scooter con accessori
--	147.112.13	1	Molla cavalletto laterale

Nr.	Code	Q.ty	Description
1	065.072.03	1	Top case
2	173.048.00	1	Rear carrier
3	084.033.00	1	Passenger footrests
4	159.034.99	1	Side stand
5	063.145.00	1	Windscreen glass
6	088.019. --	1	R/h mirror * (originally fitted)
7	063.108.00	1	Windscreen
8	018.078.00	1	Alarm complete
9	018.079.00	1	Remote control
--	065.027.00	1	Scooter canvas cover
--	065.077.00	1	Accessoried scooter canvas cover
--	147.112.13	1	Side stand spring

* Vedi tav. N° OO Colori

* Refer to N° OO Colour table

Nr.	Codice	Q.tà	Descrizione	Nr.	Code	Q.ty	Description
15	715.100.00	1	Carburatore Gurtner PY 12 / R 437	15	715.100.00	1	Carburettor Gurtner PY 12 / R 437
19	771.146.00	1	Cilindro acqua F12	19	771.146.00	1	Cylinder assy
48	024.044.00	1	Motorino avviamento	48	024.044.00	1	Starter motor
62	771.144.00	1	Pistone Ø 40 acqua	62	771.144.00	1	Piston assy Ø 40
77	777.017.00	1	Testa con resche con tappo	77	777.017.00	1	Head assy
82	782.021.00	1	Volano magnete	82	782.021.00	1	Magneto flywheel assy
111	711.008.00	1	Candela con resistore	111	711.008.00	1	Spark plug
172	717.003.00	1	Cinghia di trasmissione	172	717.003.00	1	V- belt
212	721.078.00	1	Coperchio frizione ventilato completo	212	721.078.00	1	Clutch cover
213	721.056.00	1	Coperchio trasmissione	213	721.056.00	1	Gear group cover
214	721.059.00	1	Coperchio lato volano con supporto pompa	214	721.059.00	1	Cover
219	721.060.00	1	Coperchio pompa olio con gommini	219	721.060.00	1	Oil pump cover
381	771.162.00	1	Imbiellaggio	381	771.162.00	1	Crankshaft
382	771.118.00	1	Biella completa	382	771.118.00	1	Connecting rod
601	760.043.00	1	Puleggia anteriore fissa	601	760.043.00	1	Primary fixed pulley
604	760.059.00	1	Puleggia anteriore mobile con boccola	604	760.059.00	1	Primary pulley
606	760.062.00	1	Collettore aspirazione	606	760.062.00	1	Intake manifold
641	764.011.00	1	Pompa olio completa	641	764.011.00	1	Oil pump assy
681	771.142.00	1	Serie segmenti Ø 40	681	771.142.00	1	Piston ring set Ø 40
701	770.022.00	1	Coppia carter	701	770.022.00	1	Crankcase assy
912	701.044.00	1	Albero messa in moto	912	701.044.00	1	Kick start shaft
914	701.051.00	1	Albero uscita moto completo Z=43	914	701.051.00	1	Drive shaft assy Z=43
916	701.058.00	1	Albero trasmissione Z=13	916	701.058.00	1	Gear shaft Z=13
2118	721.077.00	1	Convogliatore uscita aria rosso	2118	721.077.00	1	Air shroud (red)
2119	071.393.03	1	Convogliatore entrata aria nero	2119	071.393.03	1	Cover (black)
2436	724.054.00	2	Gommino chiusura fori carter	2436	724.054.00	2	Rubber cover
2448	724.055.00	3	Gommino perno traino pompa	2448	724.055.00	3	Grommet
2479	724.075.00	1	Gommino silent-block carter	2479	724.075.00	1	Rubber
2485	724.052.00	1	Raccordo plastica sfiato olio	2485	724.052.00	1	Oil breather pipe
2492	724.048.00	1	Tappo alimentazione olio	2492	724.048.00	1	Oil plug
2493	724.049.00	3	Tassello di traino	2493	724.049.00	3	Dowels
2497	724.056.00	1	Tubo acqua pompa-cilindro	2497	724.056.00	1	Water pump hose
2601	726.048.00	1	Campana frizione completa	2601	726.048.00	1	Clutch housing
2626	726.018.00	1	Puleggia secondaria fissa completa	2626	726.018.00	1	Secondary fixed pulley
2627	726.019.00	1	Puleggia secondaria mobile completa	2627	726.019.00	1	Secondary pulley
2642	726.045.00	1	Cappellotto porta tasselli	2642	726.045.00	1	Dowelholder cap
2664	726.021.00	1	Piastrina ritegno paraolio	2664	726.021.00	1	Plate
2665	726.022.00	1	Piastrina ingranaggio doppio intermedio E/S	2665	726.022.00	1	Idle gear plate
2667	726.023.00	1	Piastrina traino puleggia anteriore fissa	2667	726.023.00	1	Drive pulley lock washer
2669	726.044.00	1	Piastra coperchio frizione	2669	726.044.00	1	Cover
2688	726.026.00	1	Scodellino dentato messa in moto	2688	726.026.00	1	Drive plate

Nr.	Codice	Q.tà	Descrizione
2689	726.025.00	1	Scodellino porta molla variatore
3135	731.009.00	1	Elemento filtrante
3520	735.038.00	1	Frizione centrifuga completa
4040	740.142.00	1	Ingranaggio doppio intermedio Z=14/52
4041	740.121.00	1	Ingranaggio doppio intermedio E/S c/boccola
4043	740.122.00	1	Corona avviamento elettrico Z=71
4048	740.123.00	1	Ingranaggio conduttore pompa olio
4066	740.124.00	1	Ingranaggio scorrevole messa in moto
4085	740.125.00	1	Ruota libera completa
4618	746.039.00	1	Molla puleggia secondaria mobile
4626	746.044.00	1	Molla scorrevole messa in moto
4645	746.059.00	3	Molla richiamo ceppi frizione
4665	746.042.00	1	Molla ritorno leva messa in moto
4680	746.045.00	1	Molla a disco ingranaggio doppio intermedio
5104	751.084.00	1	Distanziale Ø 18x23x6.5
5105	751.041.00	1	Boccola albero messa in moto Ø 15x20x30
5108	751.042.00	1	Boccola flangiata corona E/S
5113	751.043.00	1	Gabbia KBK Ø 10x14x12,5 spinotto
5127	751.081.00	1	Boccola puleggia anteriore mobile
5148	104.028.00	1	Cuscinetto Ø 17x40x12
5150	751.046.00	1	Cuscinetto Ø 17x40x12 (6203)
5151	751.047.00	2	Cuscinetto Ø 10x30x9
5179	751.072.00	2	Cuscinetto Ø 17x35x10 (6003/2RS)
5305	753.158.00	2	Anello di tenuta OR Ø 36x1
5315	753.105.00	1	Anello di tenuta OR Ø 13.3x2.4
5320	753.129.00	1	Guarnizione base cilindro
5327	753.120.00	1	Guarnizione coperchio messa in moto
5328	753.121.00	1	Guarnizione coperchio trasmissione
5339	753.109.00	1	Guarnizione statore volano
5347	753.110.00	1	Guarnizione valvola lamelle
5359	753.112.00	1	Guarnizione vite scarico olio
5384	753.034.00	1	Paraolio Ø 10x18x4 G101840
5602	756.085.00	6	Massa centrifuga foro Ø 9.8
5603	756.078.00	1	Perno pompa acqua con girante
5612	756.080.00	1	Termostato
5615	756.029.00	2	Grano riferimento carter
5616	756.030.00	4	Grano riferimento coperchi
5640	756.070.00	2	Perno Ø 8x32
5653	756.079.00	3	Perno traino girante pompa
5661	756.024.00	1	Rullo ingranaggio condotto pompa RV4
5662	756.071.00	1	Rullo Ø 3x11.8
5668	756.099.00	2	Rullino guida variatore
5670	756.073.00	1	Spinotto Ø10x33

Nr.	Code	Q.ty	Description
2689	726.025.00	1	Spring holder
3135	731.009.00	1	Filtering part
3520	735.038.00	1	Clutch assy
4040	740.142.00	1	Idle gear assy Z=14/52
4041	740.121.00	1	Idle gear assy E/S
4043	740.122.00	1	Kick star sprocket Z=71
4048	740.123.00	1	Pump drive gear
4066	740.124.00	1	Kick start pinion gear
4085	740.125.00	1	Free wheel assy
4618	746.039.00	1	Secondary pulley spring
4626	746.044.00	1	Kick start thrust spring
4645	746.059.00	3	Clutch pads spring
4665	746.042.00	1	Kick start return spring
4680	746.045.00	1	Idle gear spring
5104	751.084.00	1	Spacer Ø 18x23x6.5
5105	751.041.00	1	Kick start shaft bush Ø 15x20x30
5108	751.042.00	1	Bush
5113	751.043.00	1	Cage KBK Ø 10x14x12,5
5127	751.081.00	1	Primary pulley bush
5148	104.028.00	1	Bearing Ø 17x40x12
5150	751.046.00	1	Bearing Ø 17x40x12 (6203)
5151	751.047.00	2	Bearing Ø 10x30x9
5179	751.072.00	2	Bearing Ø 17x35x10 (6003/2RS)
5305	753.158.00	2	Oil seal OR Ø 36x1
5315	753.105.00	1	Oil seal OR Ø 13.3x2.4
5320	753.129.00	1	Cylinder base gasket
5327	753.120.00	1	Sidecase gasket
5328	753.121.00	1	Gear box gasket
5339	753.109.00	1	Stator gasket
5347	753.110.00	1	Reed valve gasket
5359	753.112.00	1	Oil drain gasket
5384	753.034.00	1	Oil seal Ø 10x18x4 G101840
5602	756.085.00	6	Centrifugal roller Ø 9.8
5603	756.078.00	1	Water pump shaft
5612	756.080.00	1	Thermostat
5615	756.029.00	2	Crankcase locating dowel
5616	756.030.00	4	Gearbox locating dowel
5640	756.070.00	2	Pin Ø 8x32
5653	756.079.00	3	Water pump drive shaft
5661	756.024.00	1	Water pump spindle pin
5662	756.071.00	1	Pin Ø 3x11.8
5668	756.099.00	2	Pin guide
5670	756.073.00	1	Pin Ø 10x33

Nr.	Codice	Q.tà	Descrizione
6013	760.048.00	1	Corpo pompa acqua
6015	760.046.00	1	Valvola lamelle completa
9323	703.028.00	2	Anello fermo spinotto Ø 11,8
9351	703.003.00	1	Anello seeger albero
9353	703.005.00	1	Anello seeger albero Ø 15
9368	703.025.00	1	Anello seeger foro Ø 40 spessore 1.75
9375	703.026.00	2	Anello seeger albero Ø 19
24100	724.057.00	1	Traino girante pompa acqua
49004	749.148.00	1	Fascetta tubo pompa olio
49005	749.270.00	1	Fascetta antimanomissione flangia aspirazione
49006	167.031.00	2	Fascetta tubo acqua
49015	749.107.00	1	Chiavetta volano magnete
49022	749.223.00	1	Kit tubini unione testa-carburatore
49040	749.210.00	1	Dado M10x1.25
49041	749.181.00	1	Dado M10x1.25 H=8
49055	749.182.00	1	Dado M28x1 (CH=41) H=4
49057	749.183.00	4	Dado M 7x1 fissaggio testa
49058	749.184.00	1	Dado M10x1 H=5.8 (CH=24)
49070	749.186.00	1	Distanziale cuscinetto paraolio frizione
49072	749.212.00	1	Distanziale Ø 21,9x17,5x4,5
49077	749.187.00	1	Distanziale attacco carter
49084	749.188.00	4	Prigioniero fissaggio testa M 7x1x109
49108	749.021.00	3	Rondella grower Ø 6
49129	749.189.00	1	Rondella acciaio blu Ø 15,1x28x1
49148	749.222.00	1	Rondella acciaio Ø 13.2x20x1.3
49162	749.206.00	1	Rondella acciaio blu Ø 14x29x1
49212	184.009.00	2	Vite T.C.B. M5x14 taglio croce
49230	749.088.00	2	Vite T.C.B. M4x10 taglio croce
49232	749.140.00	3	Vite t.c.b. M6x12
49237	749.095.00	2	Vite T.C.C.E. M 5x14
49238	749.065.00	3	Vite T.C.C.E. M 5x20
49243	749.036.00	2	Vite T.C.C.E. M 6x16
49244	749.037.00	9	Vite T.C.C.E. M 6x20
49245	749.068.00	3	Vite T.C.C.E. M 6x25
49247	749.039.00	8	Vite T.C.C.E. M 6x35
49255	749.176.00	3	Vite T.C.C.E. M 6x12
49285	749.191.00	1	Vite T.E M8x1,25x15 scarico olio
49292	184.218.00	3	Vite antimanomissione M6
49338	749.267.00	4	Vite t.c.b. M6x20
49352	749.192.00	1	Rondella conica scodellino
49353	749.193.00	1	Rondella Ø 10.5x18x2

Nr.	Code	Q.ty	Description
6013	760.048.00	1	Water pump housing
6015	760.046.00	1	Reed valve assy
9323	703.028.00	2	Circlip Ø 11,8
9351	703.003.00	1	Kick start circlip
9353	703.005.00	1	Kick start circlip Ø 15
9368	703.025.00	1	Circlip Ø 40
9375	703.026.00	2	Circlip Ø 19
24100	724.057.00	1	Water pump shaft
49004	749.148.00	1	Clamp
49005	749.270.00	1	Antitampering clamp
49006	167.031.00	2	Clamp
49015	749.107.00	1	Woodruff key
49022	749.223.00	1	Carburettor heater hose set
49040	749.210.00	1	Nut M10x1.25
49041	749.181.00	1	Nut M10x1.25 H=8
49055	749.182.00	1	Nut M28x1 (CH=41)
49057	749.183.00	4	Nut M7x1
49058	749.184.00	1	Nut M10x1 H=5.8
49070	749.186.00	1	Spacer
49072	749.212.00	1	Spacer Ø 21,9x17,5x4,5
49077	749.187.00	1	Spacer
49084	749.188.00	4	Cylinder head stud
49108	749.021.00	3	Washer Ø 6
49129	749.189.00	1	Washer Ø 15,1x28x1
49148	749.222.00	1	Washer Ø 13.2x20x1.3
49162	749.206.00	1	Washer Ø 14x29x1
49212	184.009.00	2	Screw M5x14
49230	749.088.00	2	Screw M4x10
49232	749.140.00	3	Screw M6x12
49237	749.095.00	2	Screw M5x14
49238	749.065.00	3	Screw M5x20
49243	749.036.00	2	Screw M6x16
49244	749.037.00	9	Screw M6x20
49245	749.068.00	3	Screw M6x25
49247	749.039.00	8	Screw M6x35
49255	749.176.00	3	Screw M6x12
49285	749.191.00	1	Oil drain plug M8x1,25x15
49292	184.218.00	3	Antitampering screw
49338	749.267.00	4	Screw M6x20
49352	749.192.00	1	Washer
49353	749.193.00	1	Washer Ø 10.5x18x2



Scooter F 12 LC-2D Restyling KAT EURO 2

Motore 21 MA - 21 MA engine parts

TAV. R

Nr.	Codice	Q.tà	Descrizione	Nr.	Code	Q.ty	Description
49354	749.194.00	2	Rondella Ø 8x16x2	49354	749.194.00	2	Washer Ø 8x16x2
49501	749.197.00	9	Vite T.C.C.E. M6 x 25	49501	749.197.00	9	Screw M6x25
49502	749.207.00	2	Vite T.C.C.E. M6 x 35	49502	749.207.00	2	Screw M6x35
49503	749.208.00	1	Vite T.C.C.E. M6x45 (nera)	49503	749.208.00	1	Screw M6x45 (black)
49509	749.266.00	2	Vite t.c.c.e. M6x20	49509	749.266.00	2	Screw M6x20
51101	751.066.00	2	Cuscinetto Ø 20x47x14 (83299- 9RTCS31)	51101	751.066.00	2	Bearing Ø 20x47x14 (83299- 9RTCS31)
51107	751.055.00	2	Cuscinetto Ø 8x22x7	51107	751.055.00	2	Bearing Ø 8x22x7
51301	751.053.00	1	Gabbia Ø 57x61x10 (57RFN-6110A)	51301	751.053.00	1	Cage Ø 57x61x10 (57RFN-6110A)
53308	753.128.00	1	Anello di tenuta OR 53,7x1,78	53308	753.128.00	1	Oil seal 53,7x1,78
53309	753.127.00	1	Guarnizione OR Ø 2,62 esterna	53309	753.127.00	1	Gasket Ø 2,62
53310	753.130.00	1	Guarnizione OR Ø 2,62 interna	53310	753.130.00	1	Gasket Ø 2,62
53318	753.160.00	1	Anello di tenuta OR Ø 3x300	53318	753.160.00	1	Oil seal Ø 3x300
53400	753.161.00	1	Guarnizione piastra inferiore	53400	753.161.00	1	Gasket
53501	753.115.00	1	Paraolio Ø 20x30/34x5/6.1	53501	753.115.00	1	Oil seal Ø 20x30/34x5/6.1
53502	753.116.00	1	Paraolio Ø 20x42/43x8/9	53502	753.116.00	1	Oil seal Ø 20x42/43x8/9
53503	753.117.00	1	Paraolio Ø 17x28x5.5	53503	753.117.00	1	Oil seal Ø 17x28x5.5
53504	753.118.00	1	Paraolio Ø 22x32x6	53504	753.118.00	1	Oil seal Ø 22x32x6
53506	753.136.00	2	Paraolio Ø 34x39x4	53506	753.136.00	2	Oil seal Ø 34x39x4
--	740.161.00	1	Gruppo variatore con frizione	--	740.161.00	1	Variable transmission clutch set
--	771.124.00	1	Serie paraoli CY 50	--	771.124.00	1	Oil seal set
--	771.145.00	1	Pistone Ø 40,5 - 1°maggiorazione	--	771.145.00	1	1° oversized piston Ø 40,5 -
--	771.145.01	1	Pistone Ø 41 - 2°maggiorazione	--	771.145.01	1	2° oversized piston Ø 41 -
--	771.143.00	1	Serie segmenti Ø 40.5 - 1°maggiorazione	--	771.143.00	1	1° oversized piston ring set Ø 40.5 -
--	771.143.01	1	Serie segmenti Ø 41 - 2°maggiorazione	--	771.143.01	1	2° oversized piston ring set Ø 41 -
--	799.102.00	1	Serie guarnizioni MA 50	--	799.102.00	1	Gasket set
--	142.111.03	1	Motore completo EURO 2 (174.112)	--	142.111.03	1	Engine assy EURO 2 (174.112)

Scooter F 12 LC-2D Restyling KAT EURO 2

Motore 21 MA - 21 MA engine

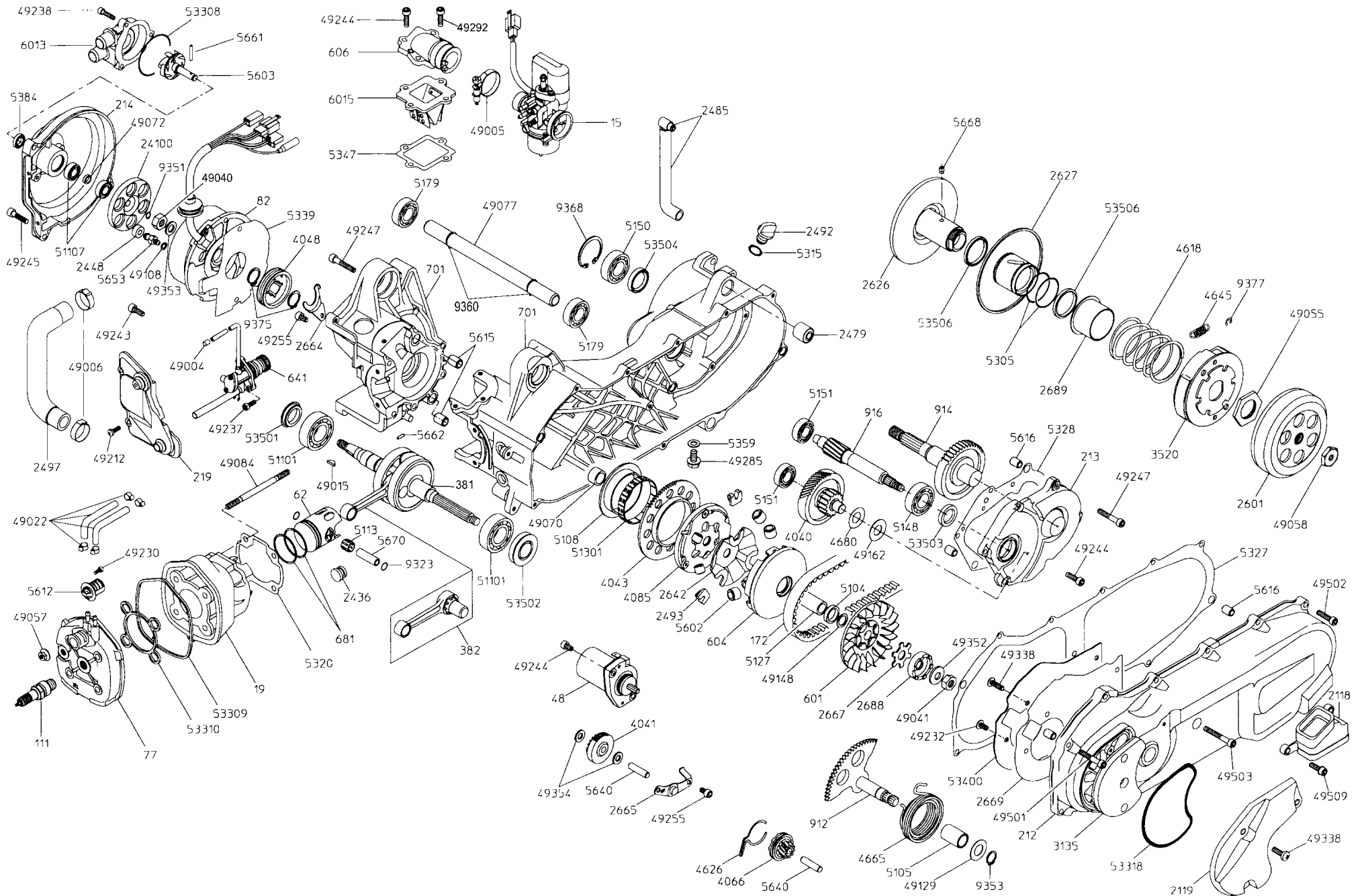

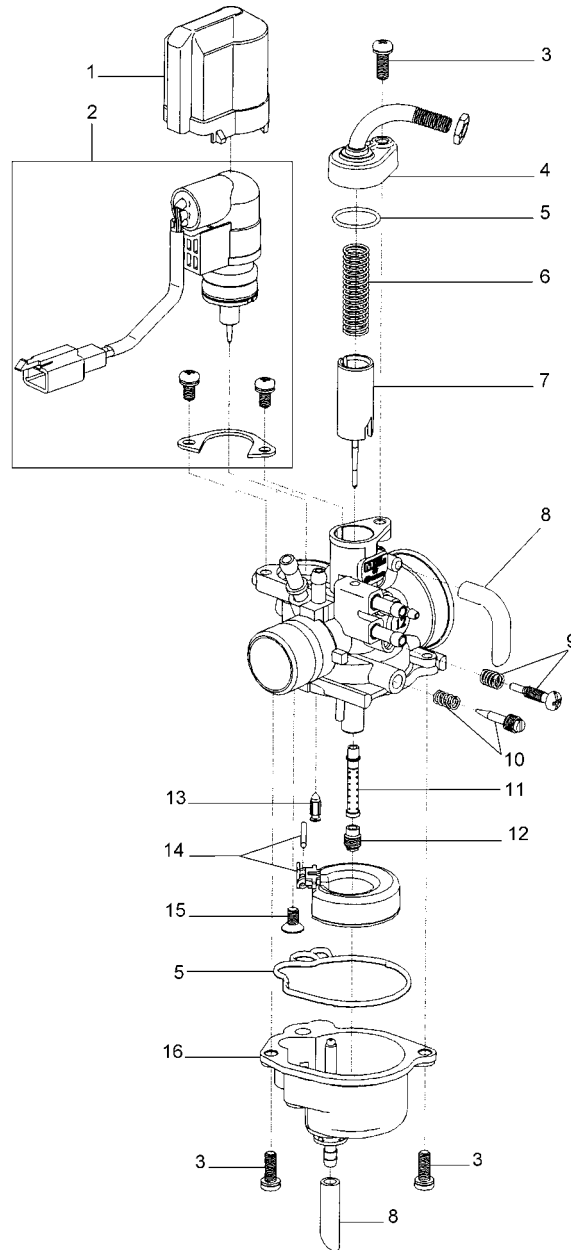

Nr.	Codice	Q.tà	Descrizione
01	623.101.00	1	Cappuccio
02	623.120.00	1	Starter completo
03	623.106.00	3	Vite
04	623.117.00	1	Coperchio completo
05	623.119.00	1	Kit guarnizioni
06	623.098.00	1	Molla valvola gas
07	623.230.00	1	Valvola gas completa
08	623.124.00	1	Kit tubi sfiato - presa aria
09	623.121.00	1	Vite regolazione valvola gas
10	623.122.00	1	Vite regolazione minimo
11	623.113.00	1	Polverizzatore
12	623.228.00	1	Getto max. Ø 56
13	623.114.00	1	Valvola a spillo
14	623.232.00	1	Galleggiante completo
15	623.107.00	1	Vite fissaggio galleggiante
16	623.233.00	1	Vaschetta completa
--	715.100.00	1	Carburatore completo Gurtner PY 12 / R 437

Nr.	Code	Q.tà	Description
01	623.101.00	1	Cap
02	623.120.00	1	Starter, complete
03	623.106.00	3	Screw
04	623.117.00	1	Cover, complete
05	623.119.00	1	Gasket set
06	623.098.00	1	Throttle valve spring
07	623.230.00	1	Throttle valve, complete
08	623.124.00	1	Breather pipe/air intake kit
09	623.121.00	1	Throttle valve adj. screw
10	623.122.00	1	Idling mix adj. screw
11	623.113.00	1	Spray nozzle
12	623.228.00	1	Max jet Ø 56
13	623.114.00	1	Needle valve
14	623.232.00	1	Float assy
15	623.107.00	1	Float clamp screw
16	623.233.00	1	Float chamber
--	715.100.00	1	Carburettor assy Gurtner PY 12 / R 437